

# UPPER SAUCON FIRE DEPARTMENT 1 CENTER VALLEY, PA

Q117542

PUMPER

TYPHOON 4X2 CHASSIS

1500 GPM DARLEY LDMBC PUMP		HOSE LOAD:			
1000 GALLON WATER TANK		300' OF 3.00" DJ			
30 GALLON INTEGRAL CLASS "A" FOAM		1000' OF 5.00" LDH			
		400' OF 2.00" DJ			
COMPT.	OPENING	INTERIOR DIMENSION			
L1/R1	40W 59H	42W	25H	12D	UPPER
		42W	30H	26D	LOWER
L2/R2	54W 25H	56W	25H	12D	
L3/R3	54W 59H	56W	25H	12D	UPPER
		56W	30H	26D	LOWER
B1	36W 21H	38W	30H	26D	

THIS DRAWING IS FOR REFERENCE PURPOSES. ALL DIMENSIONS ARE SUBJECT TO MINOR VARIATIONS DUE TO MANUFACTURING PROCESSES.

This print is the property of E-ONE, Inc. and is loaned to you subject to return on demand, unless otherwise agreed to in writing by E-ONE, Inc. Its contents are confidential and must not be copied or submitted to third parties for use or examination.

HOSEBED HEIGHT:  
(FOR REFERENCE ONLY)  
TO TAILBOARD: 46"  
TO GROUND: 70±2"

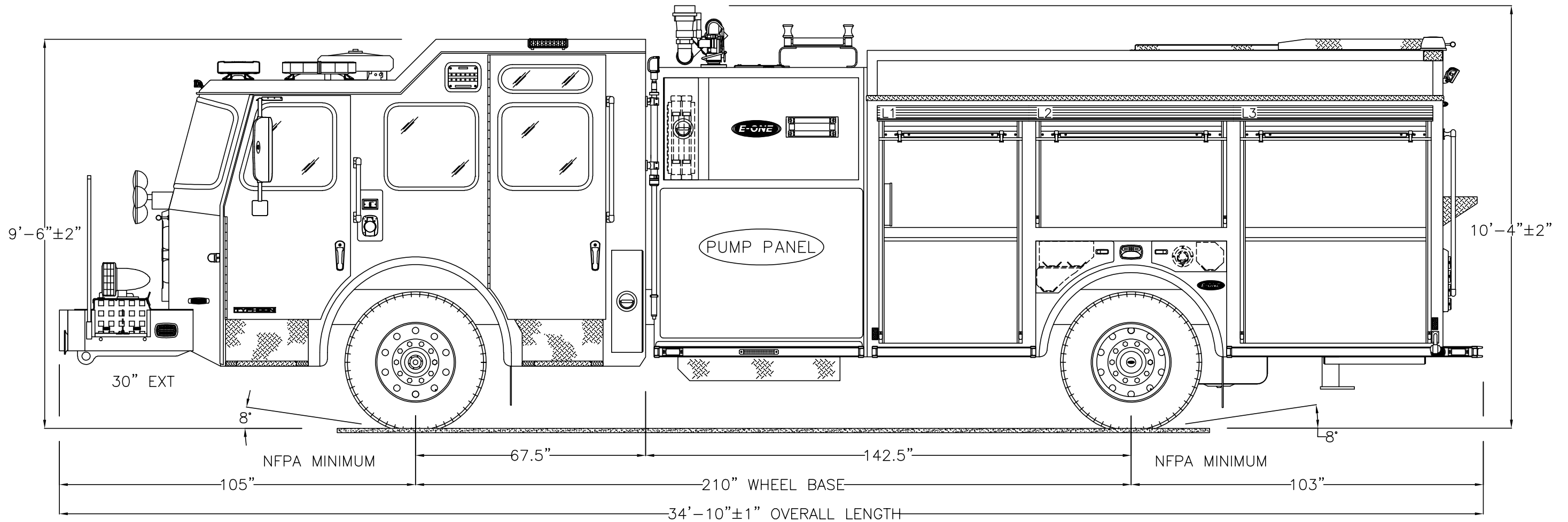
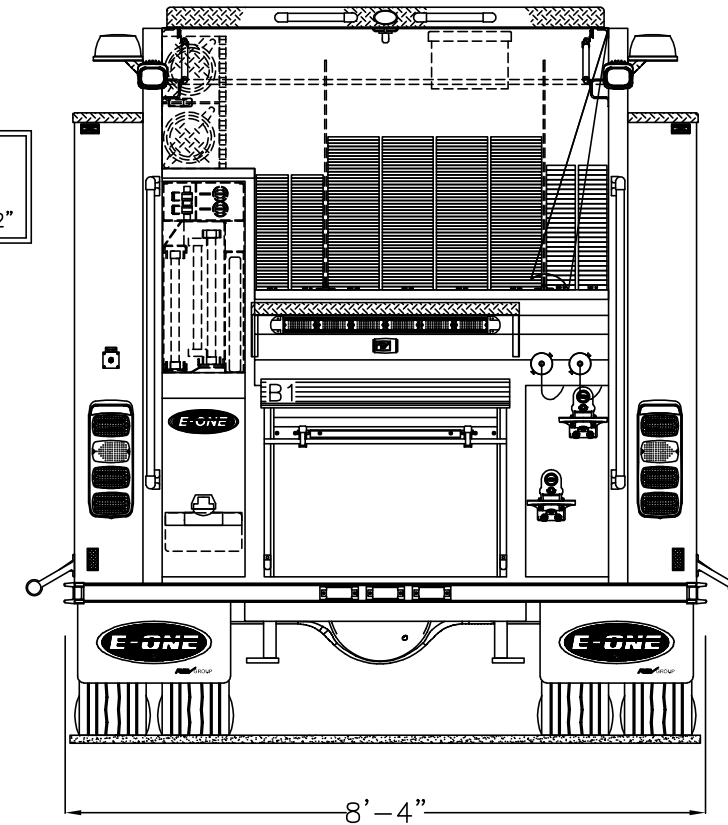
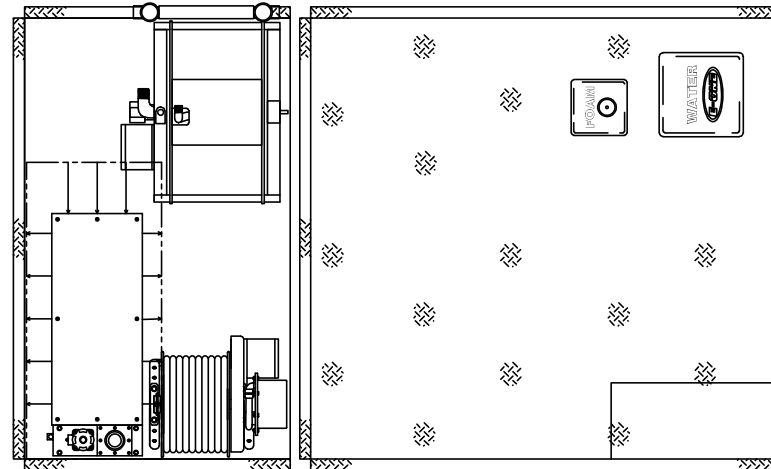

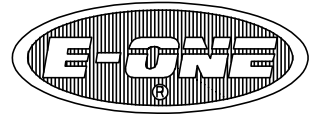

# UPPER SAUCON FIRE DEPARTMENT 1 CENTER VALLEY, PA

Q117542  
PUMPER  
TYPHOON 4X2 CHASSIS

THIS DRAWING IS FOR REFERENCE PURPOSES. ALL DIMENSIONS ARE  
SUBJECT TO MINOR VARIATIONS DUE TO MANUFACTURING PROCESSES.

This print is the property of E-ONE, Inc. and is loaned to you  
subject to return on demand, unless otherwise agreed to in writing by  
E-ONE, Inc. Its contents are confidential and must not be  
copied or submitted to third parties for use or examination.

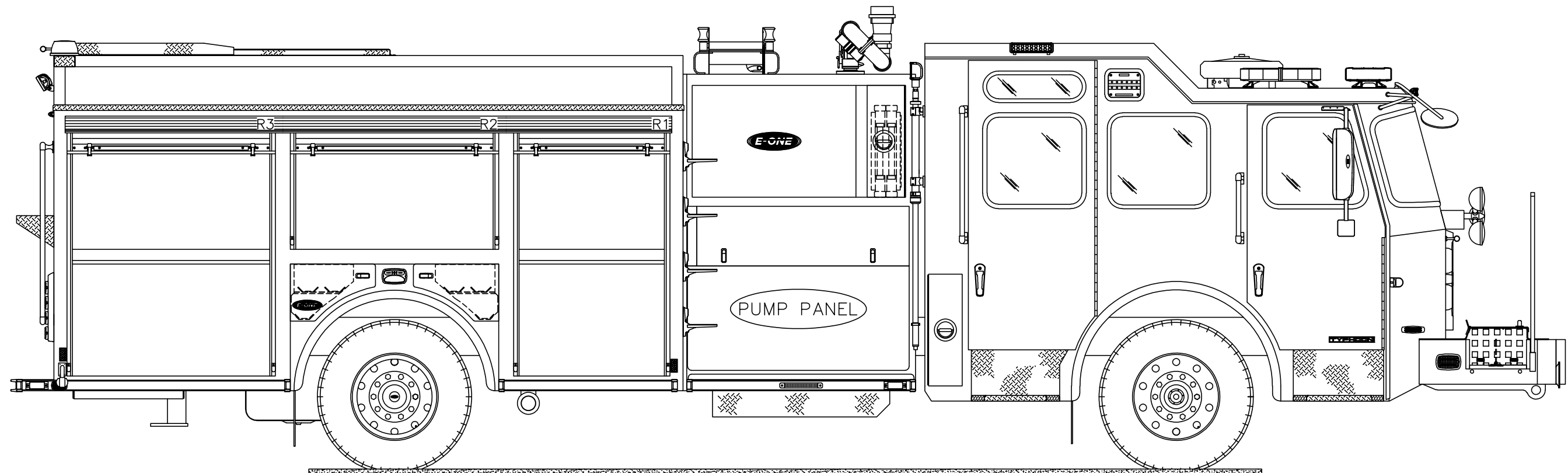
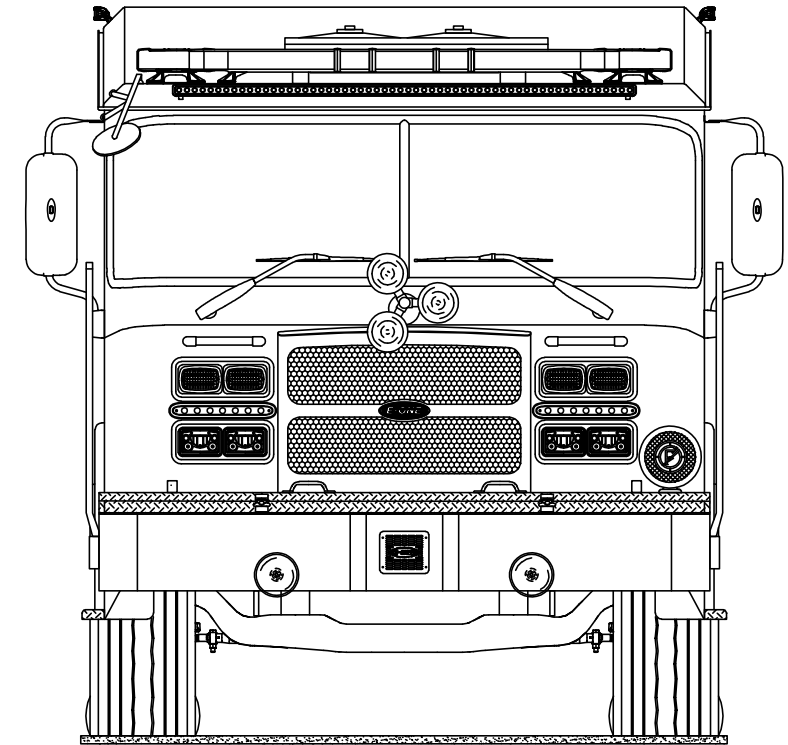

DRAWN BY	REV	DESCRIPTION	DATE	APPROVED
DRODMAN	A	QUOTE REVIEW 2	2022-JUN-06	DRODMAN
		APPROVAL REVISIONS		SHEET 2 OF 2