

E-ONE, INC. OCALA, FL

SO.138801
eMAX AERIAL BODY
TYPHOON X CHASSIS
HP78 AERIAL LADDER

THIS DRAWING IS FOR REFERENCE PURPOSES. ALL DIMENSIONS ARE
SUBJECT TO MINOR VARIATIONS DUE TO MANUFACTURING PROCESSES.

APPROVED FOR PRODUCTION

DESIGNER: _____ DATE: _____

1500 GPM eMAX PUMP 500 GALLON WATER TANK			HOSE LOAD: STD.			
COMPT.	OPENING		INTERIOR DIMENSION			
L1	58W	52H	60W 60W	35H 26H	24D 26D	UPPER LOWER
L2	40W	31H	40W	35H	24D	
L3	40W	31H	40W	21H 14H	21D 24D	UPPER LOWER
L4	24W	52H	26W 26W	35H 26H	24D 26D	UPPER LOWER
R1	58W	52H	60W 60W	35H 26H	23D 26D	UPPER LOWER
R2	47W	26H	45W	26H	26D	
B1	21W	28H	TURNTABLE ACCESS ONLY			
T1	10W	28H	VERTICAL LADDER STORAGE			
T2	11W	28H	VERTICAL LADDER STORAGE			
T3	23W	9H	PIKE POLE/ATTIC LADDER TUNNEL			
GROUND LADDERS						
ITEM	LADDER LENGTH	MODEL NUMBER	QTY			
A	35' 3-SECT	PEL3-35	1			
B	28' 2-SECT	PEL-28	1			
C	16' ROOF	PRL-16	1			
D	14' ROOF	PRL-14	1		ON AERIAL	
E	10' FOLDING	FL-10	1			
F	LITTLE GIANT	MODEL 17	1			

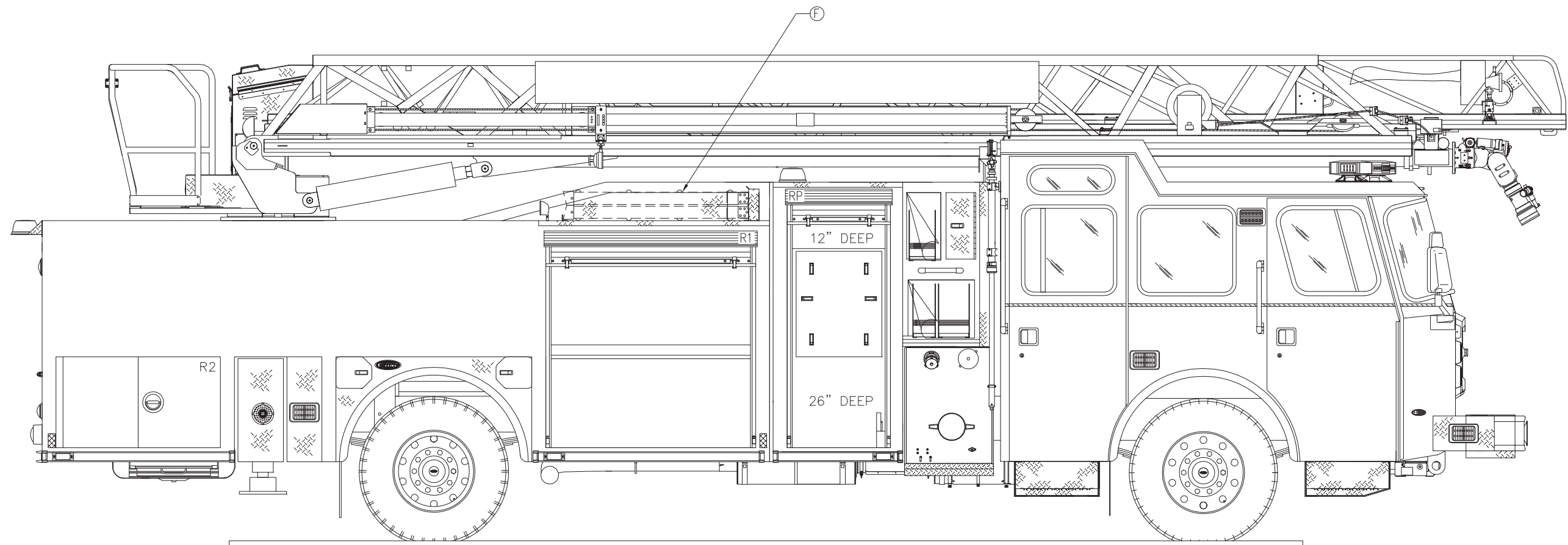
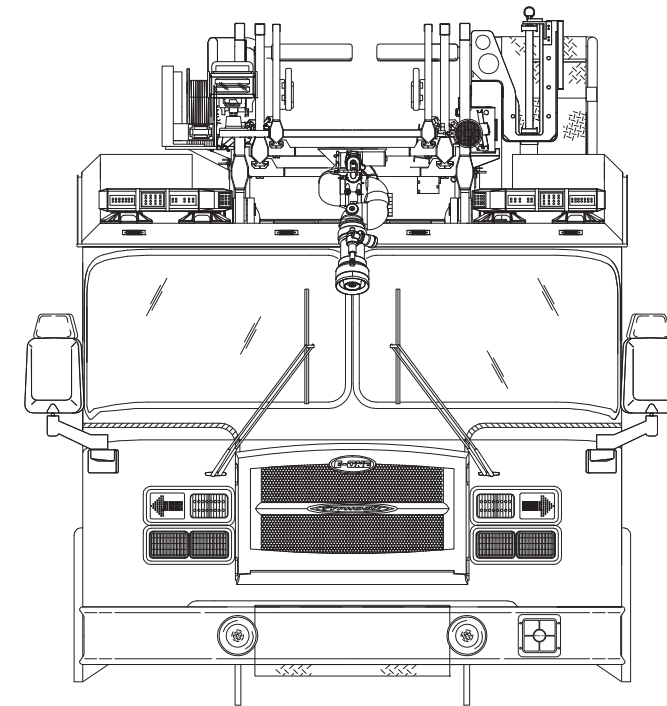

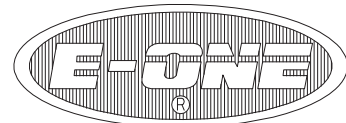

E-ONE, INC. OCALA, FL

SO.138801
eMAX AERIAL BODY
TYPHOON X CHASSIS
HP78 AERIAL LADDER

THIS DRAWING IS FOR REFERENCE PURPOSES. ALL DIMENSIONS ARE
SUBJECT TO MINOR VARIATIONS DUE TO MANUFACTURING PROCESSES.

APPROVED FOR PRODUCTION

DESIGNER: _____ DATE: _____

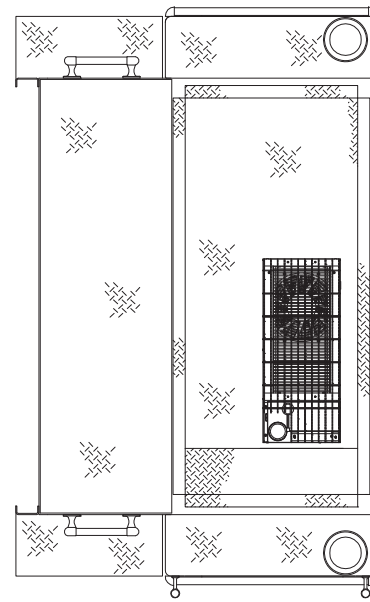

TOP VIEW OF PUMP MODULE

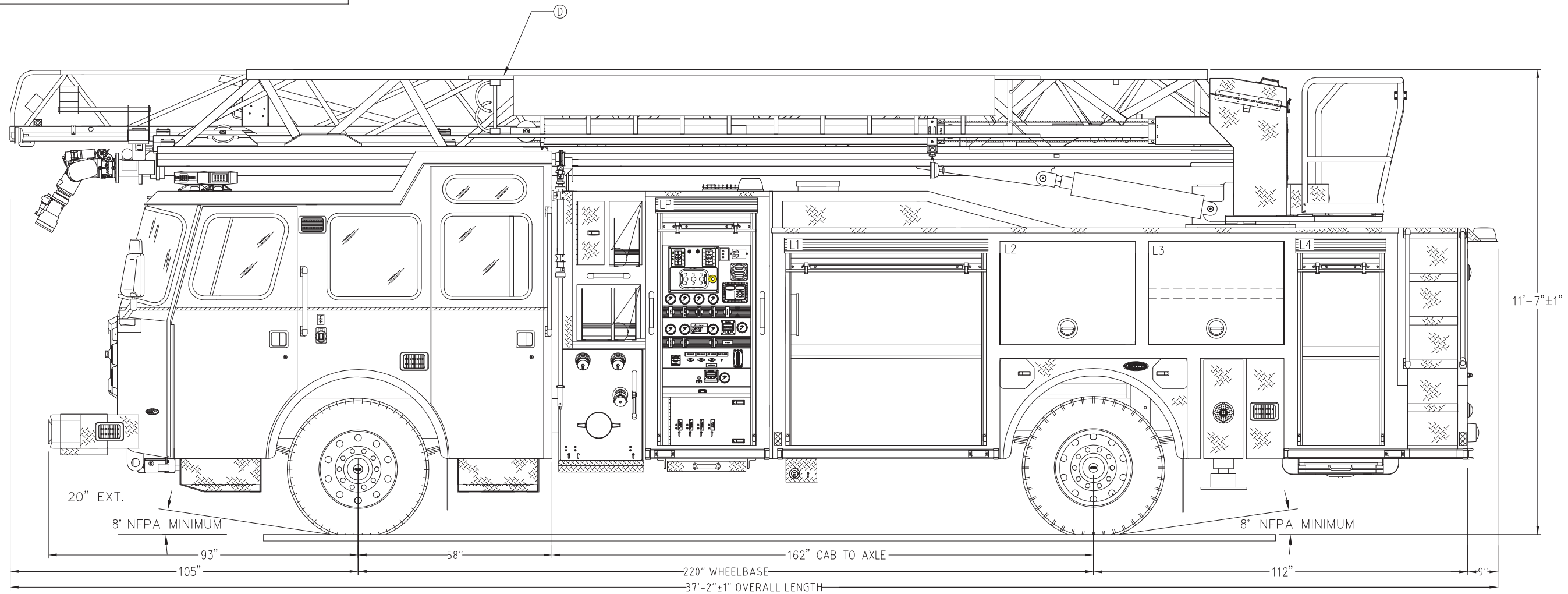
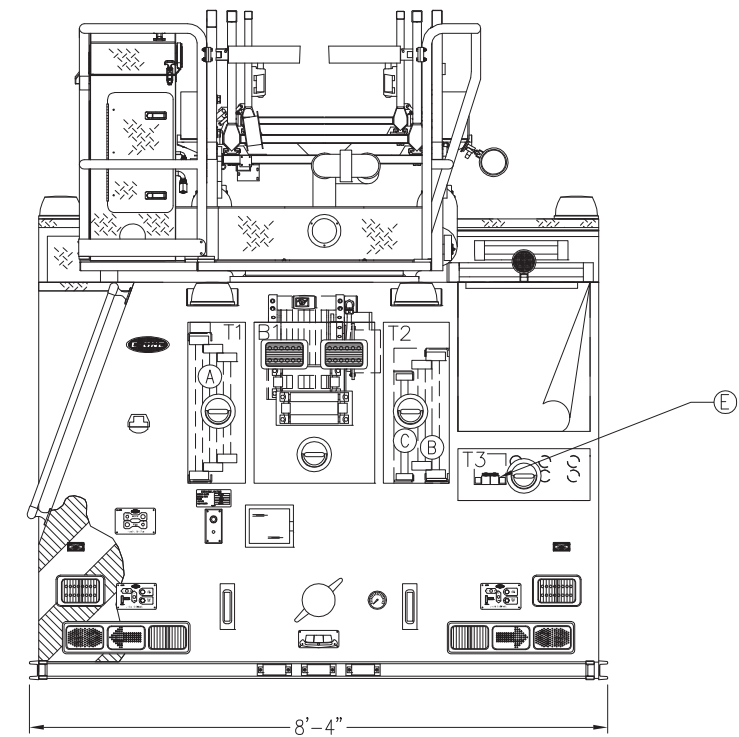

KMARQUES	A	INITIAL RELEASE	2014-JAN-15	AKELKAR
DRAWN BY	REV	DESCRIPTION	DATE	APPROVED
		APPROVAL REVISIONS		SHEET 1 OF 2