

MARCUS HOOK TRAINER FIRE DEPT
 MARCUS HOOK, PA
 SO# 137921 / Q54476
 CUSTOM 24 PUMPER
 TYPHOON X MEDIUM 4X2 CHASSIS

2000 GPM HALE QMAX PUMP	HOSE LOAD:
750 GALLON UPF POLY III WATER	250' OF 1.75" DJ
30 GALLON UPF POLY III FOAM "B"	1100' OF 5.0" LDH
8KW HARRISON MCR HYDR GENERATOR	500' OF 3.00" DJ
ELKHART 8500 VULCAN RF MONITOR	250' OF 2.50" DJ
	250' OF 2.50" DJ

COMPT.	OPENING	INTERIOR DIMENSION			
L1	22W 59H	24W 25H 12D	UPPER		
R1	22W 37H	24W 30H 26D	LOWER		
L2	54W 25H	56W 25H 12D			
R2	56W 12H	56W 12H 12D			
L3	48W 59H	36W 25H 12D	FRONT UPPER		
		36W 30H 26D	FRONT LOWER		
		14W 25H 10D	REAR UPPER		
		14W 30H 24D	REAR LOWER		
R3	48W 37H	36W 30H 26D	FRONT UPPER		
		14W 30H 10D	FRONT LOWER		
		14W 30H 24D	REAR UPPER		
		14W 30H 24D	REAR LOWER		
B1	36W 37H	38W 7H 12D	UPPER		
		38W 30H 25D	LOWER		

THIS DRAWING IS FOR REFERENCE PURPOSES. ALL DIMENSIONS ARE SUBJECT TO MINOR VARIATIONS DUE TO MANUFACTURING PROCESSES.

APPROVED FOR PRODUCTION

DESIGNER: _____ DATE: 1/17/2013

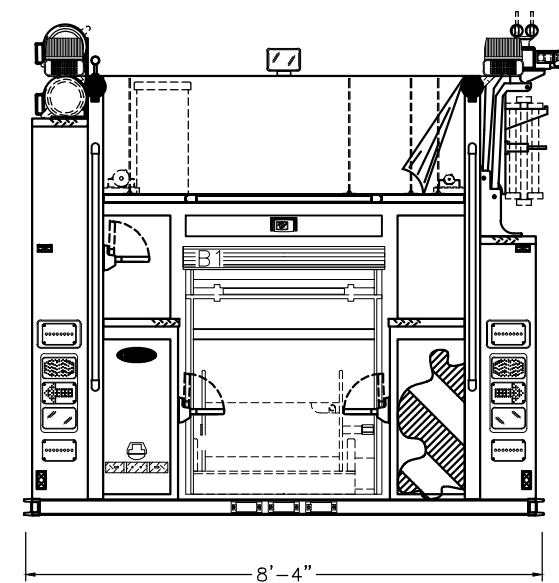

HOSEBED HEIGHT:
 (FOR REFERENCE ONLY)
 TO TAILBOARD: 59"
 TO GROUND: 83"

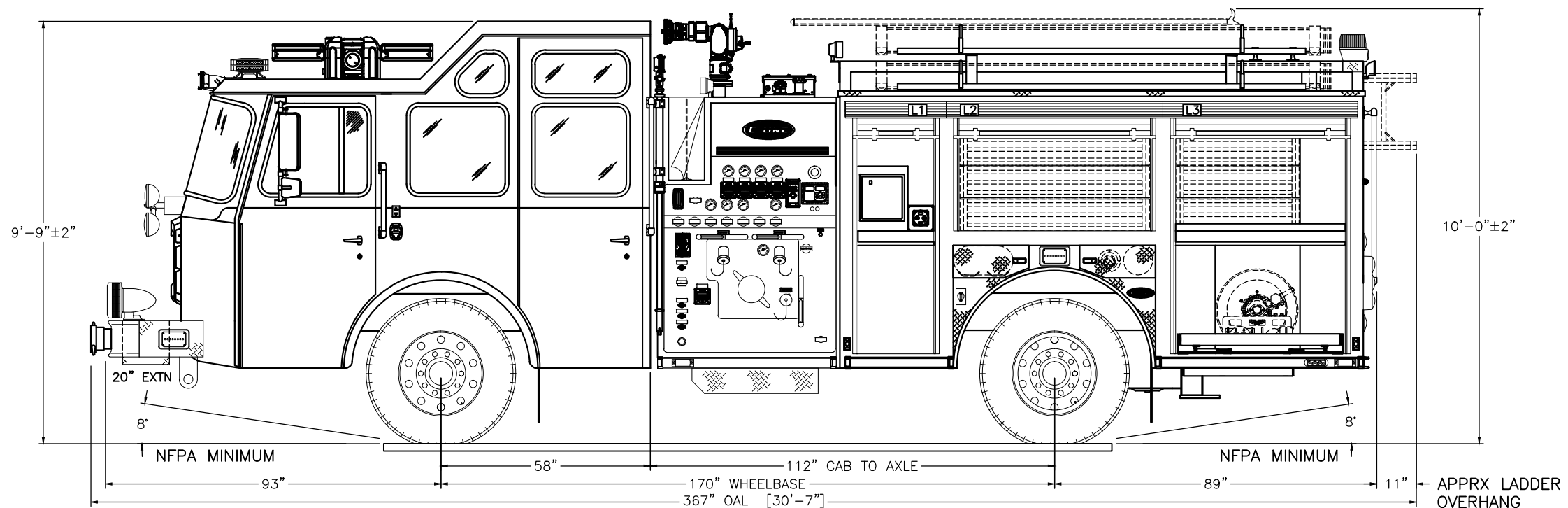

REV	C	ENG REV	03-22-2013	MB
REV	B	W/P	01-17-2013	MB
REV	A	INITIAL RELEASE	2012-05-24	W
DRAWN BY	REV	DESCRIPTION	DATE	APPROVED
		PROPOSAL REVISIONS		SHEET 1 OF 2

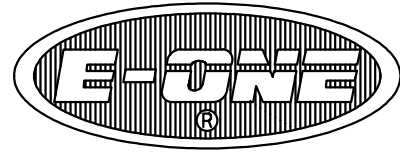

MARCUS HOOK TRAINER FIRE DEPT
 MARCUS HOOK, PA
 SO# 137921 / Q54476
 CUSTOM 24 PUMPER
 TYPHOON X MEDIUM 4X2 CHASSIS

APPROVED FOR PRODUCTION
 DESIGNER: _____ DATE: 1/17/2013

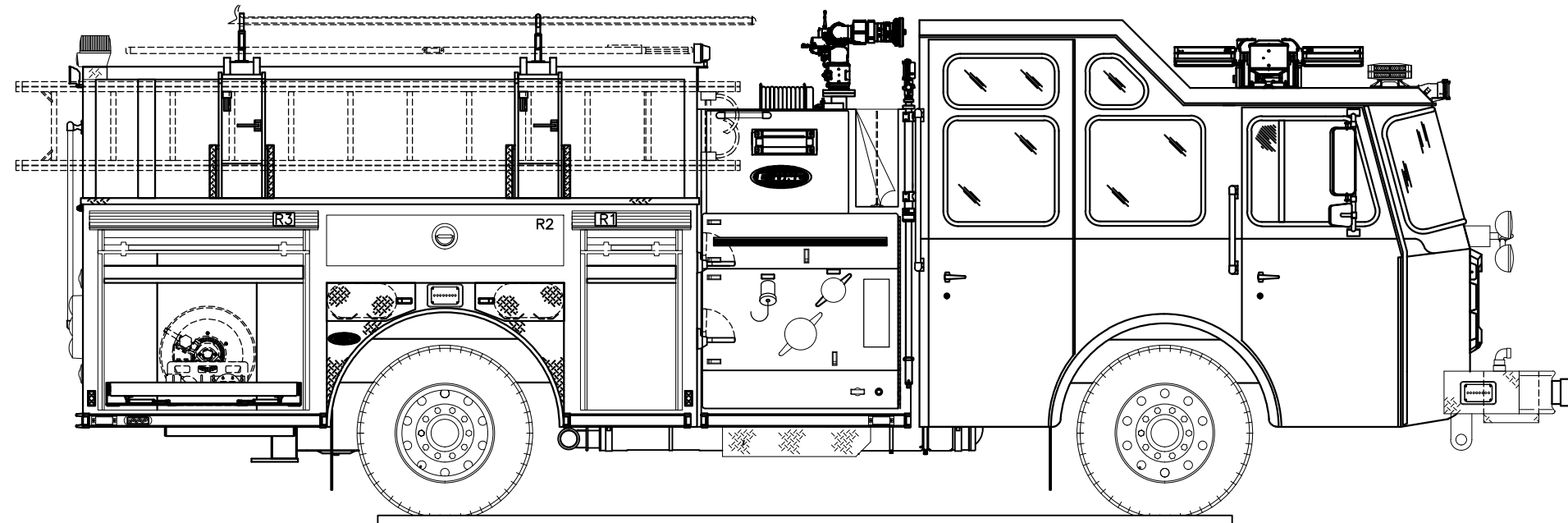
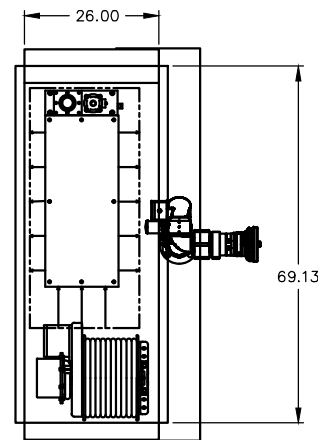
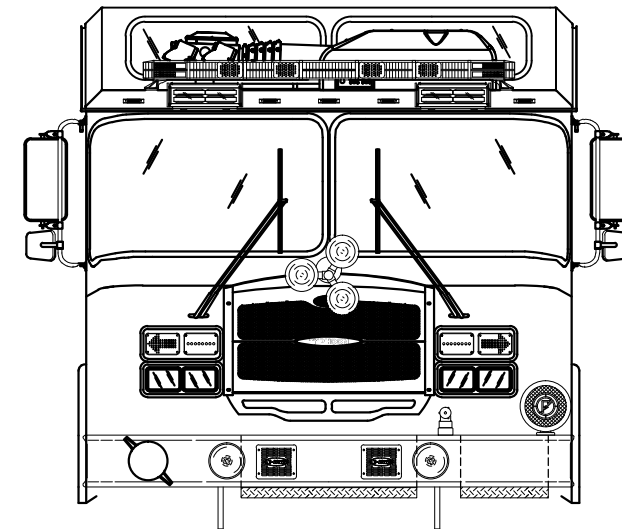

DB	C	ENG REV	03-22-2013	DB
DB	B	TRP	01-17-2013	DB
W	B	INITIAL RELEASE	2012-02-01	W
DRAWN BY	REV	DESCRIPTION	DATE	APPROVED
		PROPOSAL REVISIONS		SHEET 2 OF 2