



HARLEYSVILLE COMMUNITY FIRE COMPANY HARLEYSVILLE, PA.

SO#140440 / Q75827

PUMPER 42
TYPHOON 2X / 4X2 CHASSIS

2000 GPM WATEROUS CSU PUMP		HOSE LOAD:	
1000 GALLON WATER		500' OF 3.00" DJ	
40 GALLON INTEGRAL CLASS "A" FOAM		400' OF 2.50" DJ	
		300' OF 1.75" DJ	
		1500' OF 5.00" LDH	
COMPT.	OPENING	INTERIOR DIMENSION	
L1/R1	40W 59H	42W 35H 12D	UPPER
		42W 30H 26D	LOWER
L2/R2	54W 25H	56W 25H 12D	
L3/R3	54W 59H	56W 25H 12D	UPPER
		42W 30H 26D	LOWER
		14W 30H 24D	REAR
B1	36W 44H	38W 30H 25D	UPPER
		38W 30H 26D	LOWER

THIS DRAWING IS FOR REFERENCE PURPOSES. ALL DIMENSIONS ARE SUBJECT TO MINOR VARIATIONS DUE TO MANUFACTURING PROCESSES.

APPROVED FOR PRODUCTION

DESIGNER: M. MILDNER DATE: 2016-MAR-28

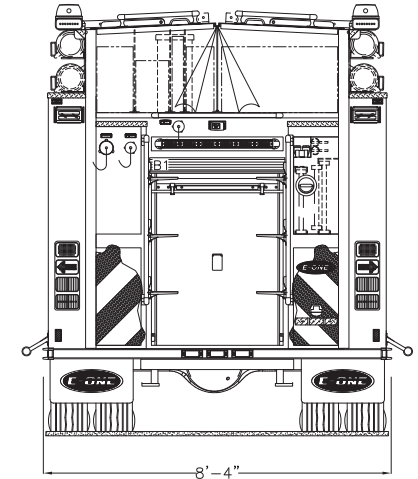
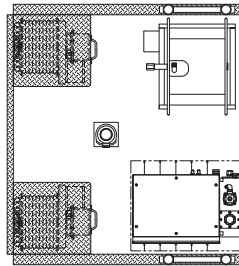

HOSEBED HEIGHT:
(FOR REFERENCE ONLY)
TO TAILBOARD: 68"
TO GROUND: 92"

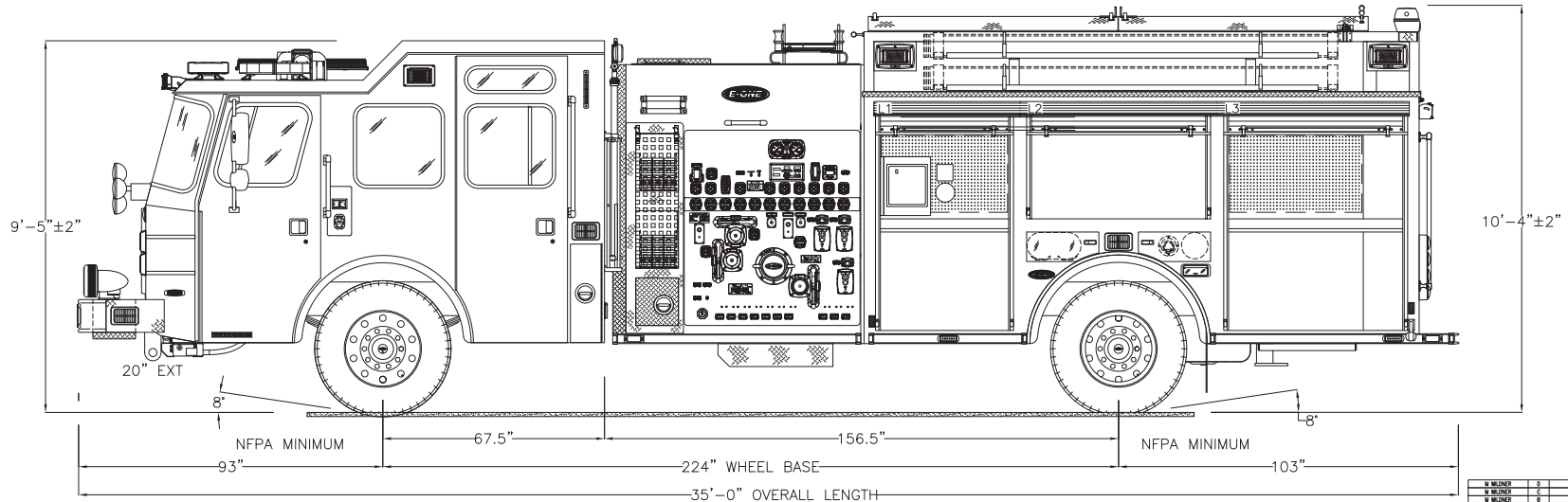

NO.	DATE	DESCRIPTION	BY	APPROVED
1	2016-MAR-28	ISSUE FOR PRODUCTION	M. MILDNER	M. MILDNER
2	2016-MAR-28	REVISED	M. MILDNER	M. MILDNER
3	2016-MAR-28	REVISED	M. MILDNER	M. MILDNER
4	2016-MAR-28	REVISED	M. MILDNER	M. MILDNER
5	2016-MAR-28	REVISED	M. MILDNER	M. MILDNER
6	2016-MAR-28	REVISED	M. MILDNER	M. MILDNER
7	2016-MAR-28	REVISED	M. MILDNER	M. MILDNER
8	2016-MAR-28	REVISED	M. MILDNER	M. MILDNER
9	2016-MAR-28	REVISED	M. MILDNER	M. MILDNER
10	2016-MAR-28	REVISED	M. MILDNER	M. MILDNER
11	2016-MAR-28	REVISED	M. MILDNER	M. MILDNER
12	2016-MAR-28	REVISED	M. MILDNER	M. MILDNER
13	2016-MAR-28	REVISED	M. MILDNER	M. MILDNER
14	2016-MAR-28	REVISED	M. MILDNER	M. MILDNER
15	2016-MAR-28	REVISED	M. MILDNER	M. MILDNER
16	2016-MAR-28	REVISED	M. MILDNER	M. MILDNER
17	2016-MAR-28	REVISED	M. MILDNER	M. MILDNER
18	2016-MAR-28	REVISED	M. MILDNER	M. MILDNER
19	2016-MAR-28	REVISED	M. MILDNER	M. MILDNER
20	2016-MAR-28	REVISED	M. MILDNER	M. MILDNER
21	2016-MAR-28	REVISED	M. MILDNER	M. MILDNER
22	2016-MAR-28	REVISED	M. MILDNER	M. MILDNER
23	2016-MAR-28	REVISED	M. MILDNER	M. MILDNER
24	2016-MAR-28	REVISED	M. MILDNER	M. MILDNER
25	2016-MAR-28	REVISED	M. MILDNER	M. MILDNER
26	2016-MAR-28	REVISED	M. MILDNER	M. MILDNER
27	2016-MAR-28	REVISED	M. MILDNER	M. MILDNER
28	2016-MAR-28	REVISED	M. MILDNER	M. MILDNER
29	2016-MAR-28	REVISED	M. MILDNER	M. MILDNER
30	2016-MAR-28	REVISED	M. MILDNER	M. MILDNER
31	2016-MAR-28	REVISED	M. MILDNER	M. MILDNER
32	2016-MAR-28	REVISED	M. MILDNER	M. MILDNER
33	2016-MAR-28	REVISED	M. MILDNER	M. MILDNER
34	2016-MAR-28	REVISED	M. MILDNER	M. MILDNER
35	2016-MAR-28	REVISED	M. MILDNER	M. MILDNER
36	2016-MAR-28	REVISED	M. MILDNER	M. MILDNER
37	2016-MAR-28	REVISED	M. MILDNER	M. MILDNER
38	2016-MAR-28	REVISED	M. MILDNER	M. MILDNER
39	2016-MAR-28	REVISED	M. MILDNER	M. MILDNER
40	2016-MAR-28	REVISED	M. MILDNER	M. MILDNER
41	2016-MAR-28	REVISED	M. MILDNER	M. MILDNER
42	2016-MAR-28	REVISED	M. MILDNER	M. MILDNER
43	2016-MAR-28	REVISED	M. MILDNER	M. MILDNER
44	2016-MAR-28	REVISED	M. MILDNER	M. MILDNER
45	2016-MAR-28	REVISED	M. MILDNER	M. MILDNER
46	2016-MAR-28	REVISED	M. MILDNER	M. MILDNER
47	2016-MAR-28	REVISED	M. MILDNER	M. MILDNER
48	2016-MAR-28	REVISED	M. MILDNER	M. MILDNER
49	2016-MAR-28	REVISED	M. MILDNER	M. MILDNER
50	2016-MAR-28	REVISED	M. MILDNER	M. MILDNER
51	2016-MAR-28	REVISED	M. MILDNER	M. MILDNER
52	2016-MAR-28	REVISED	M. MILDNER	M. MILDNER
53	2016-MAR-28	REVISED	M. MILDNER	M. MILDNER
54	2016-MAR-28	REVISED	M. MILDNER	M. MILDNER
55	2016-MAR-28	REVISED	M. MILDNER	M. MILDNER
56	2016-MAR-28	REVISED	M. MILDNER	M. MILDNER
57	2016-MAR-28	REVISED	M. MILDNER	M. MILDNER
58	2016-MAR-28	REVISED	M. MILDNER	M. MILDNER
59	2016-MAR-28	REVISED	M. MILDNER	M. MILDNER
60	2016-MAR-28	REVISED	M. MILDNER	M. MILDNER
61	2016-MAR-28	REVISED	M. MILDNER	M. MILDNER
62	2016-MAR-28	REVISED	M. MILDNER	M. MILDNER
63	2016-MAR-28	REVISED	M. MILDNER	M. MILDNER
64	2016-MAR-28	REVISED	M. MILDNER	M. MILDNER
65	2016-MAR-28	REVISED	M. MILDNER	M. MILDNER
66	2016-MAR-28	REVISED	M. MILDNER	M. MILDNER
67	2016-MAR-28	REVISED	M. MILDNER	M. MILDNER
68	2016-MAR-28	REVISED	M. MILDNER	M. MILDNER
69	2016-MAR-28	REVISED	M. MILDNER	M. MILDNER
70	2016-MAR-28	REVISED	M. MILDNER	M. MILDNER
71	2016-MAR-28	REVISED	M. MILDNER	M. MILDNER
72	2016-MAR-28	REVISED	M. MILDNER	M. MILDNER
73	2016-MAR-28	REVISED	M. MILDNER	M. MILDNER
74	2016-MAR-28	REVISED	M. MILDNER	M. MILDNER
75	2016-MAR-28	REVISED	M. MILDNER	M. MILDNER
76	2016-MAR-28	REVISED	M. MILDNER	M. MILDNER
77	2016-MAR-28	REVISED	M. MILDNER	M. MILDNER
78	2016-MAR-28	REVISED	M. MILDNER	M. MILDNER
79	2016-MAR-28	REVISED	M. MILDNER	M. MILDNER
80	2016-MAR-28	REVISED	M. MILDNER	M. MILDNER
81	2016-MAR-28	REVISED	M. MILDNER	M. MILDNER
82	2016-MAR-28	REVISED	M. MILDNER	M. MILDNER
83	2016-MAR-28	REVISED	M. MILDNER	M. MILDNER
84	2016-MAR-28	REVISED	M. MILDNER	M. MILDNER
85	2016-MAR-28	REVISED	M. MILDNER	M. MILDNER
86	2016-MAR-28	REVISED	M. MILDNER	M. MILDNER
87	2016-MAR-28	REVISED	M. MILDNER	M. MILDNER
88	2016-MAR-28	REVISED	M. MILDNER	M. MILDNER
89	2016-MAR-28	REVISED	M. MILDNER	M. MILDNER
90	2016-MAR-28	REVISED	M. MILDNER	M. MILDNER
91	2016-MAR-28	REVISED	M. MILDNER	M. MILDNER
92	2016-MAR-28	REVISED	M. MILDNER	M. MILDNER
93	2016-MAR-28	REVISED	M. MILDNER	M. MILDNER
94	2016-MAR-28	REVISED	M. MILDNER	M. MILDNER
95	2016-MAR-28	REVISED	M. MILDNER	M. MILDNER
96	2016-MAR-28	REVISED	M. MILDNER	M. MILDNER
97	2016-MAR-28	REVISED	M. MILDNER	M. MILDNER
98	2016-MAR-28	REVISED	M. MILDNER	M. MILDNER
99	2016-MAR-28	REVISED	M. MILDNER	M. MILDNER
100	2016-MAR-28	REVISED	M. MILDNER	M. MILDNER



HARLEYSVILLE COMMUNITY FIRE COMPANY
HARLEYSVILLE, PA.
SO#140440 / Q75827
PUMPER 42
TYPHOON 2X / 4X2 CHASSIS

THIS DRAWING IS FOR REFERENCE PURPOSES. ALL DIMENSIONS ARE
 SUBJECT TO MINOR VARIATIONS DUE TO MANUFACTURING PROCESSES.

APPROVED FOR PRODUCTION

DESIGNER: M. MILDNER DATE: 2016-MAR-28

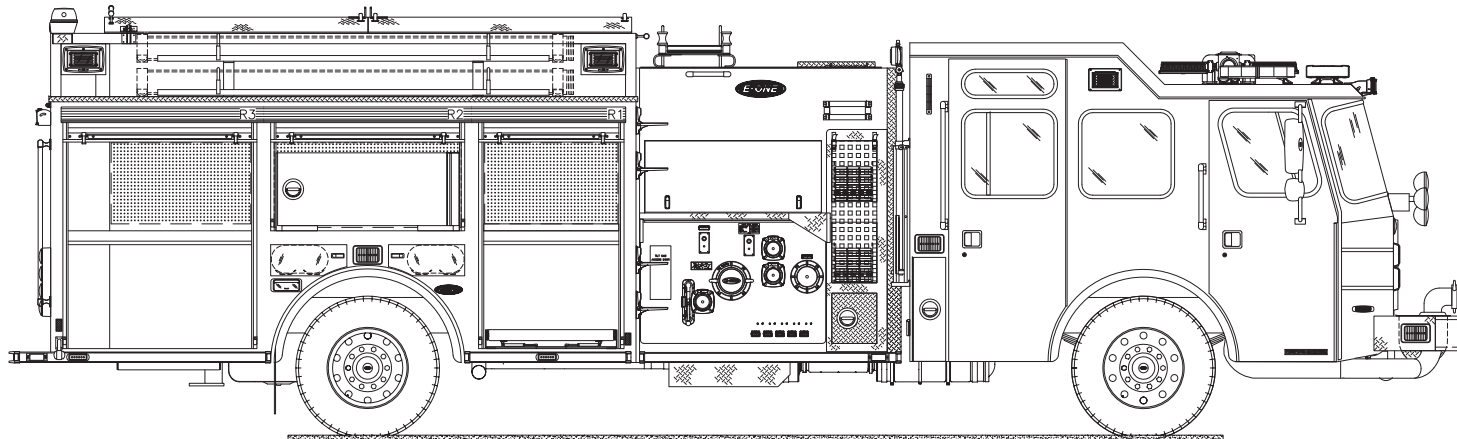
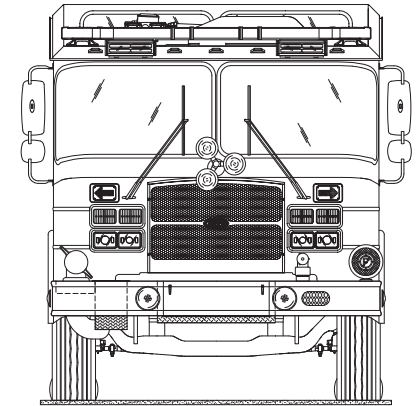

DESIGNER	REV	DESCRIPTION	DATE	APPROVED
M. MILDNER	D	ACTION ITEMS	2016-MAY-20	M. MILDNER
M. MILDNER	C	ACTION ITEMS	2016-APR-27	M. MILDNER
M. MILDNER	B	ORDER REVIEW #2 REV	2016-MAR-24	M. MILDNER
M. MILDNER	A	INITIAL RELEASE	2016-MAR-18	M. MILDNER
DESIGN BY	REV	DESCRIPTION	DATE	APPROVED