

AVOCA FIRE DEPARTMENT AVOCA, PA.

S.O. 141823 / QUOTE 77327

CUSTOM 42 PUMPER

E-ONE TYPHOON X MEDIUM CAB 4X2 CHASSIS

1500 GPM HALE QMAX PUMP 750 GALLON WATER 30 GALLON CLASS "A" FOAM CELL	HOSE LOAD:	
	450' OF 2.50" DJ	
	1200' OF 5.00" LDH	
	200' OF 3.00" DJ	
	600' OF 3.00" DJ	

COMPT.	OPENING		INTERIOR DIMENSION			
L1/R1	40W	59H	42W	25H	12D	UPPER
			42W	30H	26D	LOWER
L2/R2	54W	25H	56W	25H	12D	
L3/R3	54W	59H	56W	25H	12D	UPPER
			56W	30H	26D	LOWER
B1	36W	20H	38W	30H	27D	

THIS DRAWING IS FOR REFERENCE PURPOSES. ALL DIMENSIONS ARE SUBJECT TO MINOR VARIATIONS DUE TO MANUFACTURING PROCESSES.

APPROVED FOR PRODUCTION

DESIGNER: _____ DATE: _____

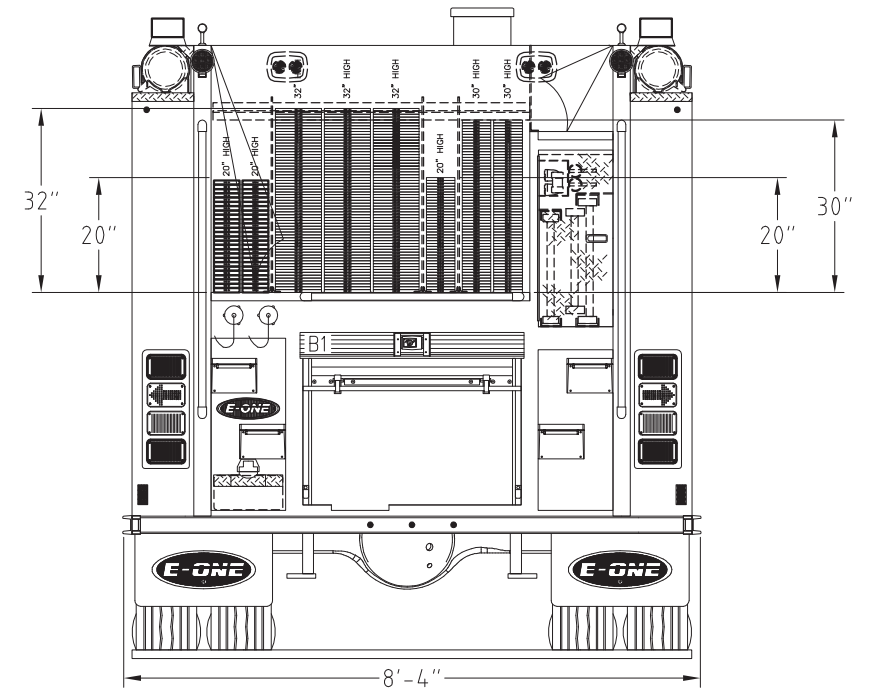
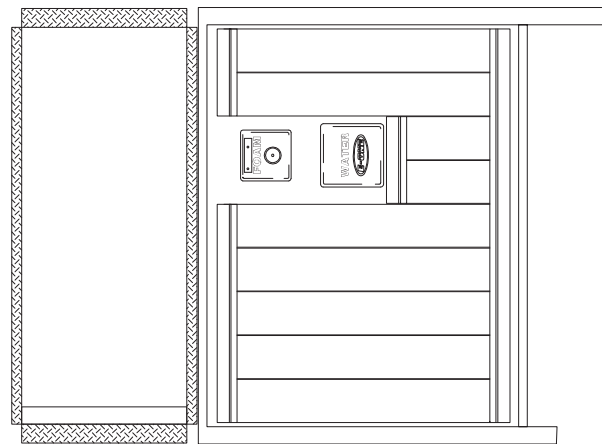

HOSEBED HEIGHT:
(FOR REFERENCE ONLY)
TO TAILBOARD: 39"
TO GROUND: 63"

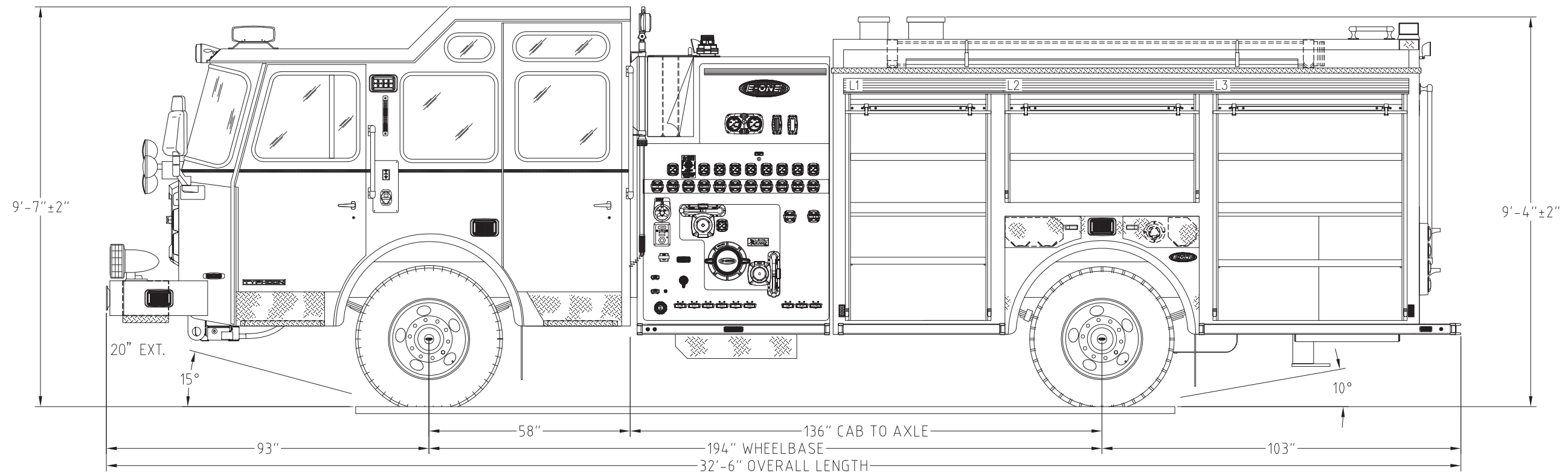

KMARQUES	B	RFP	2017-NOV-06	AKELKAR
RSTILL	A	INITIAL RELEASE / ORDER REVIEW 1	2017-OCT-13	RSTILL
DRAWN BY	REV	DESCRIPTION	DATE	APPROVED
		APPROVAL REVISIONS		SHEET 1 OF 2

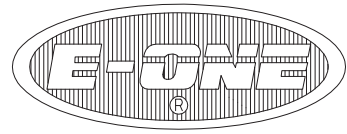

AVOCA FIRE DEPARTMENT

AVOCA, PA.

S.O. 141823 / QUOTE 77327
 CUSTOM 42 PUMPER
 E-ONE TYPHOON X MEDIUM CAB 4X2 CHASSIS

THIS DRAWING IS FOR REFERENCE PURPOSES. ALL DIMENSIONS ARE
 SUBJECT TO MINOR VARIATIONS DUE TO MANUFACTURING PROCESSES.

APPROVED FOR PRODUCTION

DESIGNER: _____ DATE: _____

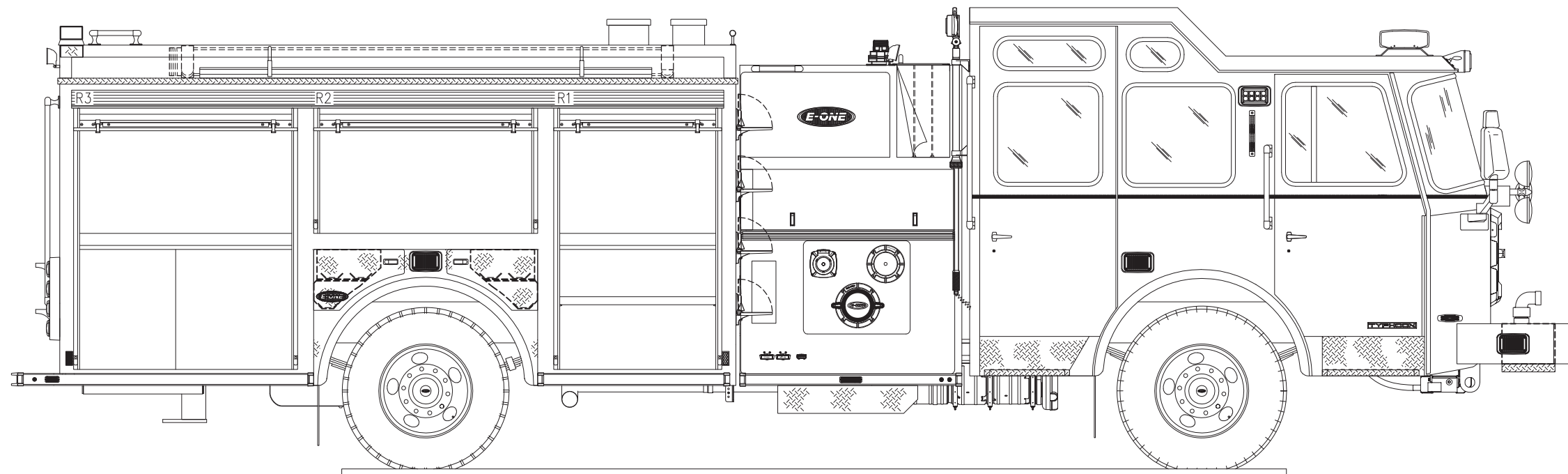
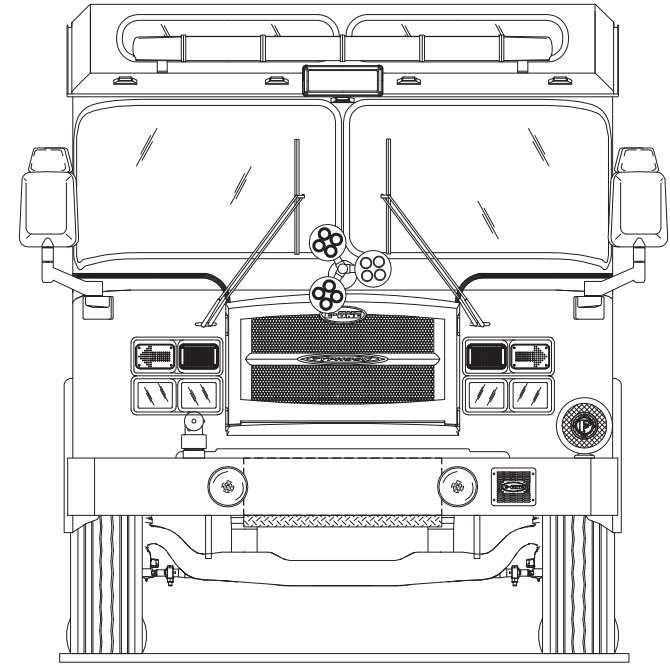

KMARQUES	B	RFP	2017-NOV-06	AKELKAR
RSTLL	A	INITIAL RELEASE / ORDER REVIEW 1	2017-OCT-13	RSTLL
DRAWN BY	REV	DESCRIPTION	DATE	APPROVED
APPROVAL REVISIONS				SHEET 2 OF 2